

BMMB

Full Color HD Camera



BMMBHTC5005XESLW

- Full Color Bullet
- 1/2.8"SONY Starvis Back-illuminated CMOS Sensor
- 2.7-15mm Motorized Lens
- Suport Warm white (4000K) , up to 40m

www.longse.com

Data Subject To Change Without Notice

SPECIFICATION	
Model NO.	BMMBHTC5005XESLW
Video Output Mode	AHD: 8M@15fps, 5M@20fps/12.5fps, 4M/2M@30fps/25fps; CVI: 8M@15fps/12.5fps, 4M/2M@30fps/25fps TVI: 8M@15fps/12.5fps, 5M@20fps/12.5fps, 4M/2M@30fps/25fps;
Camera	
Image Sensor	1/2.8" SONY Starvis Back-illuminated CMOS sensor
Image Resolution	8M:3840*2160 5M:2592*1944 4M:2560*1440 2M:1920*1080
TV System	PAL/NTSC
Electronic Shutter	Auto
Minimun Illumination	0.005Lux
Scanning System	Progressive Scan
Lens	
Focus Length	2.7-13.5mm Motor Zoom
Focus Control	Auto
Lens Type	Auto
Night Vision	
IR Cut Filter	YES
Infrared LED	NO, Suport Warm white (4000K)
Light Distanc	up to 40m
IR Status	AGC auto control
Camera Features	
Starlight	/
Day/Night	YES/NO
OSD Menu	YES
WDR	YES
UTC	YES
Noise Reduction	3DNR
Coaxial Audio	/
White Balance	AUTO / MANUAL
Gain Control	AUTO
General	
Housing	Metal, IP67
Bracket	YES
Operation Temperature	-10℃ ~ +60℃ RH95% Max
Storage Temperature	-20℃ ~ +60℃ RH95% Max
Power Source	DC12V±10%, 750mA
Dimension	268(W) x 95(H) x 88(D)mm
Weight	1.5Kg

www.longse.com

Data Subject To Change Without Notice

Technical Specifications

Model	BMMB
Material	Aluminum & SECC & PC
Dimension(WxHxD)	95 x 88 x 268 mm
Weight	1.50kg
Color	White
Operating Temperature	-20°C ~ +60°C
Humidity	< 95% RH
Junction Box	B320

Dimensions (mm)

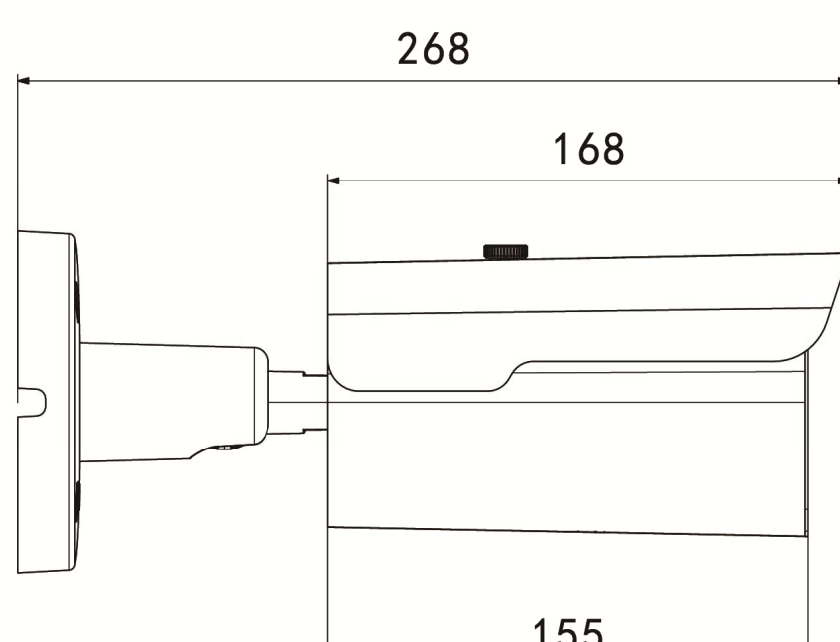

www.longse.com

Data Subject To Change Without Notice